

DHB - Dual Half Bridge

Part Number #41213

Basic Specifications

Electrical

- Output current
 - Continuous DC current 20 A (total)
 - Peak surge current 500 A
- Max operating frequency 50 kHz @ 28 V
- Switching delay, typical
 - High to low 6.5 μ sec
 - Low to high 6.5 μ sec
- Input threshold, typical
 - High 2.8 V
 - Low 2.1 V
- Operating voltage
 - 7.0 V to 55 V with under voltage lockout
- Input impedance
 - 10 k Ω pull-up to 5 V

Physical

- Size 31.4 x 38.0 x 14.0 mm
- Weight approximately 60 grams plus connectors
- Connectors
 - Power: 2 pin DTP Male
 - Outputs: 2 pin DTP Female
 - Inputs: 2 pin DTM Male
- Maximum case temperature 125 °C

Truth Table

Input	Output
Low	Switched to Bat-
High	Switched to Bat+

Compatibility

- All MoTeC ECUs
- All MoTeC Dash Loggers



MoTeC's **DHB Dual Half Bridge** is a high current amplifier which allows low current auxiliary outputs to drive high current loads such as motors.

Applications

- Servo motor e.g. active wing control, boat trim control, inlet runner length control, variable valve lift.
- Motor speed control e.g. electric water pump, thermo fan, fuel pump.
- Solenoid control.

Features

- Contains two high current Half Bridge outputs.
- Can drive a single motor in two directions, or can drive two motors in a single direction.
- Capable of high speed PWM which can be used for speed control of motors and for other purposes.
Note that the controlling device must perform the control function, such as PWM speed control, direction control or servo control.
- Fully sealed case suitable for under bonnet mounting.

Dimensions

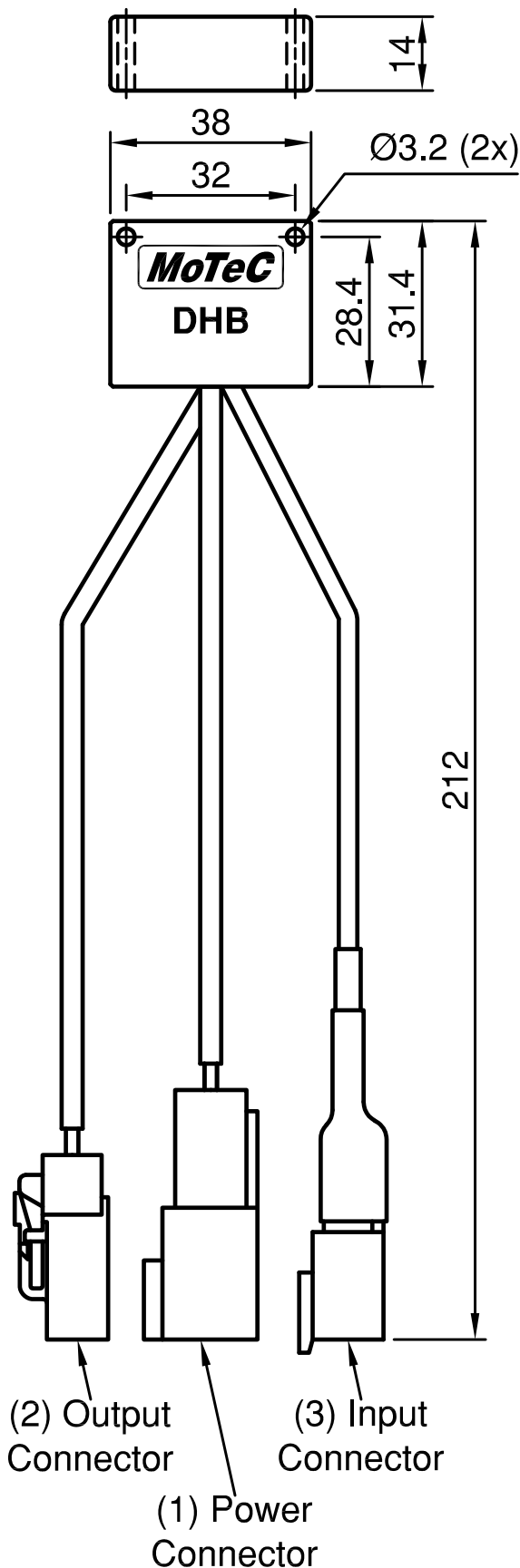

Connectors and Pinout

Connector 1 - Power

2 pin DTP connector
Mating connector #68104

Pin	Name	Function
1	Bat-	Battery Negative
2	Bat+	Battery Positive

Connector 2 - Outputs

2 pin DTP connector
Mating connector #68103

Pin	Name	Function
1	Out1	Output 1
2	Out2	Output 2

Connector 3 - Inputs

2 pin DTM connector
Mating connector #68051

Pin	Name	Function
1	In1	Input 1
2	In2	Input 2

Wiring

- Connect to the auxiliary outputs of any MoTeC ECU or Dash Logger.
- Both Bat- and Bat+ wires rated at motor current.

Drive Single Motor in Two Directions

Speed control: PWM either Input1 or Input 2.

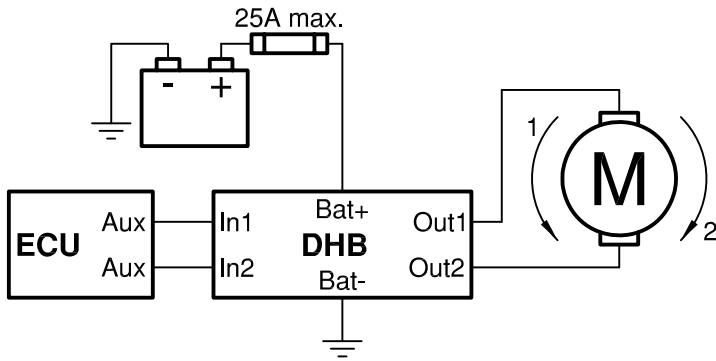

Input 1	Input 2	Motor
Low	Low	OFF
Low	High	Direction 1
High	Low	Direction 2
High	High	OFF

Drive Two Grounded Motors in a Single Direction

Speed control: PWM Input, High Duty = Fast.

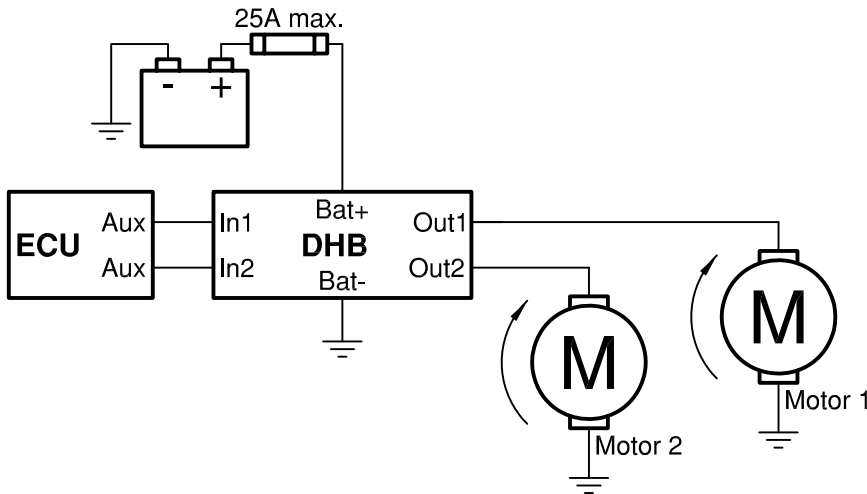

Input 1	Motor 1
Low	OFF
High	ON

Input 2	Motor 2
Low	OFF
High	ON

Drive Two Powered Motors in a Single Direction

Speed control: PWM Input, Low Duty = Fast.

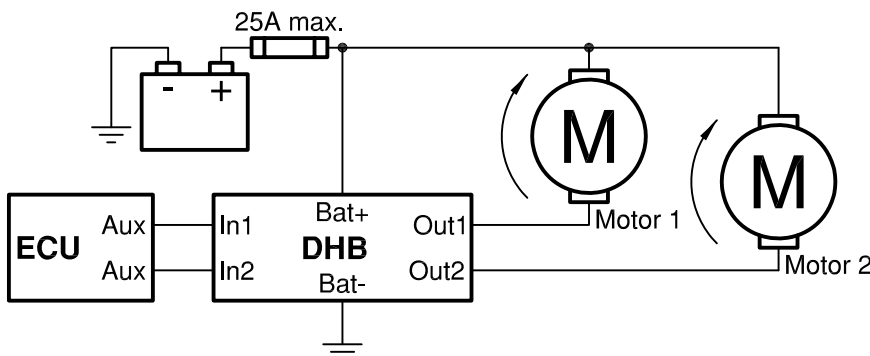

Input 1	Motor 1
Low	ON
High	OFF

Input 2	Motor 2
Low	ON
High	OFF